

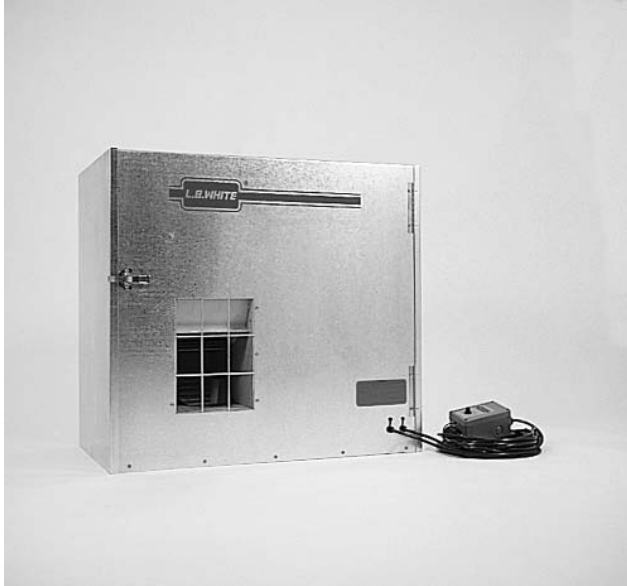

Owner's Manual and Instructions

Agricultural Animal Confinement Building Heaters



MODELS	OUTPUT	FUEL
AB230	67.4 KW	Available in either L.P. Vapor Withdrawal or Natural Gas Configurations.



Certification by:



Congratulations!

You have purchased the finest agricultural building heater available.

Your new L.B. White heater incorporates the benefits from the most experienced manufacturer of heating products using state-of-the-art technology.

We, at L.B. White, **thank you** for your confidence in our products and welcome any suggestions or comments you may have.....call us, at 608-783-5691.

ATTENTION ALL USERS

This heater is approved by Australian Gas Association as a direct gas-fired circulating heater for the heating of agricultural animal confinement buildings. The heater is approved for indoor use only. If you are considering using this product for any application other than it's intended use, contact your local agent or the L. B. White Co., Inc. in the U.S.A. at 608-783-5691. This heater has been evaluated in accordance with AG404 as well as relevant sections of AG106 and AG103. In addition, an electrical evaluation in accordance with AS3100-1990 was conducted.

Local Agent:



Quality heaters you can count on.

W6636 L.B. White Rd., Onalaska, WI 54650 ■ (800) 345-7200 ■ (608) 783-5691 ■ (608) 783-6115, fax ■ info@lbwhite.com



GENERAL HAZARD WARNING

- Failure to comply with the precautions and instructions provided with this heater, can result in:
 - Death
 - Serious bodily injury or burns
 - Property damage or loss from fire or explosion
 - Asphyxiation due to lack of adequate air supply or carbon monoxide poisoning
 - Electrical shock
- Read this Owner's Manual before installing or using this product.
- Only properly-trained service people should repair or install this heater.
- Save this Owner's Manual for future use and reference.
- Owner's Manuals and replacement labels are available at no charge. For assistance, contact L.B. White at 608-783-5691.



WARNING

- Proper gas supply pressure must be provided to the inlet of the heater.
- Refer to the heater's dataplate for proper gas supply pressure.
- Gas pressure in excess of the maximum inlet pressure specified at the heater inlet can cause fires or explosions.
- Fires or explosions can lead to serious injury, death, building damage or loss of livestock.
- Gas pressure below the minimum inlet pressure specified at the heater inlet may cause improper combustion.
- Improper combustion can lead to asphyxiation or carbon monoxide poisoning and therefore serious injury or death to humans and livestock.



WARNING

Fire and Explosion Hazard

- Not for home or recreational vehicle use.
- Installation of this heater in a home or recreational vehicle may result in a fire or explosion.
- Fire or explosions can cause property damage or loss of fire.

FOR YOUR SAFETY

Do not store or use gasoline or other flammable vapors and liquids in the vicinity of this or any other appliance.

FOR YOUR SAFETY

- If you smell gas:
1. Open windows.
 2. Don't touch electrical switches.
 3. Extinguish any open flame.
 4. Immediately call your gas supplier.



WARNING

Fire and Explosion Hazard

- Keep solid combustibles a safe distance away from the heater.
- Solid combustibles include wood or paper products, feathers, straw, and dust.
- Do not use the heater in spaces which contain or may contain volatile or airborne combustibles.
- Volatile or airborne combustibles include gasoline, solvents, paint thinner, dust particles or unknown chemicals.
- Failure to follow these instructions may result in a fire or explosion.
- Fire or explosions can lead to property damage, personal injury or loss of life.



<u>SECTION</u>	<u>PAGE</u>
General Information	3
Heater Specifications	4
Safety Precautions	5
Installation Instructions	
General	7
Air Diverter Installation Instructions	8
Hanging Instructions	9
Sediment Trap Assembly	9
Thermostat Installation	10
Manual Shut-Off Valve, Hose and Regulator Assembly	10
Start-Up Instructions	11
Shut-Down Instructions	11
Cleaning Instructions	12
Maintenance Instructions	12
Service Instructions	
Motor and Fan Wheel Assembly	13
Sail Switch and Sail (Flapper)	13
Pilot Light Assembly	14
Thermocouple	15
Gas Control Valve	16
Testing the Manual Reset High Limit Switch	16
Troubleshooting Guide	17
Electrical Connection and Ladder Diagram	26
Heater Component Function	27
Parts Identification	
Parts Schematic	28
Parts List	29
Label Identification	30
Wire Selection Table	31
Fastener Selection Table	31
Warranty Policy	32
Replacement Parts and Service	32

General Information

This Owner's Manual includes all options and accessories commonly used on this heater. However, depending on the configuration purchased, some options and accessories may not be included.

When calling for technical service assistance, or for other specific information, always have model number, configuration number and serial number available. This information is contained on the dataplate. The dataplate is located on the exterior of the burner end.

This manual will instruct you in the operation and care of your unit. Have your qualified installer review this manual with you so that you fully understand the heater and how it functions.

The gas supply line installation, installation of the heater, and repair and servicing of the heater requires continuing expert training and knowledge of gas heaters and should not be attempted by anyone who is not so qualified. See page 6 for definition of the necessary qualifications.

Contact your local L. B. White distributor or the L. B. White Co., Inc. for assistance, or if you have any questions about the use of the equipment or its application.

The L. B. White Co., Inc. has a policy of continuous product improvement. It reserves the right to change specifications and design without notice.

Heater Specifications

		Model	
SPECIFICATIONS		AB230	
		L.P. Gas	Natural Gas
Maximum Input		67.4 KW (242.42 MJ/h)	
Ventilation Air Required to Support Combustion		1,630 Cubic Meters per Hour	
Inlet Gas Supply Pressure Acceptable at the Inlet of the Heater for Purpose of Input Adjustment	MAX.	3.36 KPa	
	MIN.	2.75 KPa	1.13 KPa
Burner Manifold Pressure		2.50 KPa	0.75 KPa
Fuel Consumption Per Hour	MAX.	4.83 Kilograms per Hour	6.57 Cubic Meters per Hour
Motor Characteristics		Ball Bearing, 187 Watts 950 RPM	
Electrical Supply (Volts/Hz/Phase)		240/50/1	
Amp Draw	STARTING	4.5	
	CONTINUOUS OPERATION	1.2	
Dimensions L x W x H		78 CM x 46 CM x 72 CM	
Minimum Safe Distances From Nearest Combustible Materials	TOP	.3 Meters	
	SIDES	.3 Meters	
	BACK	.3 Meters	
	BLOWER OUTLET	1.83 Meters	
	GAS SUPPLY	Reference AS1596 and AG601	

Safety Precautions

WARNING **Asphyxiation Hazard**

- Do not use this heater for heating human living quarters.
- Do not use in unventilated areas.
- The flow of combustion and ventilation air must not be obstructed.
- Proper ventilation air must be provided to support the combustion air requirements of the heater being used.
- Refer to the specification section of the heater's Owner's Manual, heater dataplate, or contact the L.B. White Company to determine combustion air ventilation requirements of the heater.
- Lack of proper ventilation air will lead to improper combustion.
- Improper combustion can lead to carbon monoxide poisoning in humans leading to serious injury or death. Symptoms of carbon monoxide poisoning can include headaches, dizziness and difficulty in breathing.
- Symptoms of improper combustion affecting livestock can be disease, lower feed conversion, or death.

FUEL GAS ODOR

LP gas and natural gas have man-made odorants added specifically for detection of fuel gas leaks. If a gas leak occurs, you should be able to smell the fuel gas. THAT'S YOUR SIGNAL TO GO INTO IMMEDIATE ACTION!

- Do not take any action that could ignite the fuel gas. Do not operate any electrical switches. Do not pull any power supply or extension cords. Do not light matches or any other source of flame. Do not use your telephone.
- Get everyone out of the building and away from the area immediately.
- Close all propane (LP) gas tank or cylinder fuel supply valves, or the main fuel supply valve located at the meter if you use natural gas.
- Propane (LP) gas is heavier than air and may settle in low areas. When you have reason to suspect a propane leak, keep out of all low areas.
- Natural gas is lighter than air and can collect around rafters or ceilings.
- Use your neighbor's phone and call your fuel gas supplier and your fire department. Do not re-enter the building or area.
- Stay out of the building and away from the area until declared safe by the firefighters and your fuel gas supplier.
- **FINALLY**, let the fuel gas service person and the firefighters check for escaped gas. Have them air out the building and area before you return. Properly trained service people must repair the leak, check for further leakages, and then relight the appliance for you.

ODOR FADING -- NO ODOR DETECTED

- **Some people cannot smell well. Some people cannot smell the odor of the man-made chemical added to propane (LP) or natural gas. You must determine if you can smell the odorant in these fuel gases.**
- Learn to recognize the odor of propane (LP) gas and natural gas. Local propane (LP) gas dealers and your local natural gas supplier (utility) will be more than happy to give you a "scratch and sniff" pamphlet. Use it to become familiar with the fuel gas odor.
- Smoking can decrease your ability to smell. Being around an odor for a period of time can affect your sensitivity to that particular odor. Odors present in animal confinement buildings can mask fuel gas odor.
- The odorant in propane (LP) gas and natural gas is colorless and the intensity of its odor can fade under some circumstances.
- If there is an underground leak, the movement of gas through the soil can filter the odorant.
- Propane (LP) gas odor may differ in intensity at different levels. Since propane (LP) gas is heavier than air, there may be more odor at lower levels.
- **Always be sensitive to the slightest gas odor.** If you continue to detect any gas odor, no matter how small, treat it as a serious leak. Immediately go into action as discussed previously.

ATTENTION -- CRITICAL POINTS TO REMEMBER!

- Propane (LP) gas and natural gas have a distinctive odor. Learn to recognize these odors. (Reference "Fuel Gas Odor" and "Odor Fading" sections above.)
- If you have not been properly trained in repair and service of propane (LP) gas and natural gas fueled heaters, then do not attempt to light heater, perform service or repairs, or make any adjustments to the heater on propane (LP) gas or natural gas fuel system.
- Even if you are not properly trained in the service and repair of the heater, ALWAYS be consciously aware of the odors of propane (LP) gas and natural gas.
- A periodic "sniff test" around the heater or at the heater's joints; i.e. hose, connections, etc., is a good safety practice under any conditions. If you smell even a small amount of gas, CONTACT YOUR FUEL GAS SUPPLIER IMMEDIATELY. DO NOT WAIT!

Safety Precautions

1. Do not attempt to install, repair, or service this heater or the gas supply line unless you have continuing expert training and knowledge of gas heaters.

Qualifications for service and installation of this equipment are as follows:

- a. To be a qualified gas heater service person, you must have sufficient training and experience to handle all aspects of gas-fired heater installation, service and repair. This includes the task of installation, troubleshooting, replacement of defective parts and testing of the heater. You must be able to place the heater into a continuing safe and normal operating condition. You must completely familiarize yourself with each model heater by reading and complying with the safety instructions, labels, Owner's Manual, etc., that is provided with each heater.
 - b. To be a qualified gas installation person, you must have sufficient training and experience to handle all aspects of installing, repairing and altering gas lines, including selecting and installing the proper equipment, and selecting proper pipe and tank size to be used. This must be done in accordance with all local, state and national codes as well as the manufacturer's requirements.
2. All installations and applications of L. B. White heaters must meet all relevant local, state and national codes. Included are AG601 Gas Installation Code, electrical, and safety codes. Your local fuel gas supplier, a local licensed electrician, the local fire department or similar government agencies, or your insurance agent can help you determine code requirements.
 3. Do not move, handle, or service heater while in operation or connected to a power or fuel supply.
 4. This heater may be installed in areas subject to washdown. This heater may only be washed on the external case assembly—see Cleaning Instructions. Do not wash the interior of the heater. Use only compressed air, soft brush or dry cloth to clean the interior of the heater and its components. After external washdown, do not operate this heater until it is completely dry. In any event, do not operate the heater for at least one hour after external washdown.
 5. For safety, this heater is equipped with a manual reset high-limit switch and an air flow switch. Never operate this heater with any safety device that has been bypassed. Do not operate this heater unless all of these features are fully functioning.
 6. Do not operate the heater with its door(s) open or panel removed.
 7. Do not locate fuel gas containers or fuel supply hoses anywhere near the blower outlet of the heater.
 8. Do not block air intakes or discharge outlets of the appliance. Doing so may cause improper combustion or damage to heater components leading to property damage or animal loss.
 9. The hose assembly (if provided) shall be visually inspected on an annual basis. If it is evident there is excessive abrasion or wear, or if the hose is cut, it must be replaced prior to the heater being put into operation. The hose assembly shall be protected from animals, building materials, and contact with hot surfaces during use. The hose assembly shall be that specified by the manufacturer. See parts list.
 10. Check for gas leaks and proper function upon heater installation, before building repopulation or when relocating.
 11. This heater should be inspected for proper operation by a qualified service person before building repopulation and at least annually.
 12. Always turn off the gas supply to the heater if the appliance is not going to be used in the heating of livestock.
 13. This heater is wired for a three-wire electrical system. There is a hot lead, neutral lead and ground lead. The heater may or may not incorporate a plug in the power cord to the heater and the plug may or may not incorporate a pin for the ground wire. In any case, the heater must be properly connected into a grounded electrical supply using the ground lead in the power cord. Failure to use a properly grounded electrical supply can result in electrical shock, personal injury or death.
 14. If gas flow is interrupted and flame goes out, do not relight the heater until you are sure that all gas that may have accumulated has cleared away. In any event, do not relight the heater for at least 5 minutes.
 15. In a hanging type installation, rigid pipe or copper tubing coupled directly to the heater may cause gas leaks during movement, and therefore must not be used. Use only gas hose assemblies complying with AS1869 that are rated and approved for LP-gas and natural gas in a hanging type of installation.
 16. Installations not using the gas hose supplied with this heater must connect dimensionally using the Australian AG601 Gas Installation Code or local codes as required. (Aluminum piping or tubing shall not be used.) Copper tubing when used for conveying natural gas, shall be internally tinned or equivalently treated to resist sulphur.



WARNING

Fire or Explosion Hazard.

Can cause property damage, severe injury or death.

- Disconnect power supply before wiring to prevent electrical shock or equipment damage.
- To avoid dangerous accumulation of fuel gas, turn off gas supply at the appliance service valve before starting installation, and perform gas leak test after completion of installation.
- Do not force the gas control knob. Use only your hand to turn the gas control knob. Never use any tools. If the knob will not operate by hand, the control should be replaced by a qualified service technician. Force or attempted repair may result in fire or explosion.

1. Read all safety precautions and follow L. B. White recommendations when installing this heater. If during the installation or relocating of heater, you suspect that a part is damaged or defective, call a qualified service agency for repair or replacement.
2. Make sure the heater is properly positioned before use and is hung level. Observe and obey all minimum safe distances of the heater to the nearest combustible materials. Minimum safe distances are given on the heater nameplate and on page 4 of this manual.
3. The heater's approved gas regulator (with pressure relief valve) should be installed outside of building. Any regulators inside the buildings must be properly vented to the outside. Local, state and national codes always apply to regulator installation. Natural gas regulators with vent limiting device may be mounted indoors without venting to outdoors.
4. Insure that all accessories that ship within the heater have been removed from inside of heater and installed. This pertains to air diverters, hose, regulator, etc.
5. Make certain that a sediment trap is installed at the gas valve inlet to prevent foreign materials (pipe compound, pipe chips and scale) from entering the gas valve. Debris blown into the gas valve may cause that valve to malfunction resulting in a serious gas leak that could result in a possible fire or explosion causing loss of products, building or even life. A properly installed sediment trap will keep foreign materials from entering the gas valve and protect the safe functioning of that important safety component.
6. Any heater or appliance connected to a piping system must have an accessible, approved manual shut off valve installed within 1.83 meters of the heater it serves.

7. Check all connections for gas leaks using approved gas leak detectors. Gas leak testing is performed as follows: Check all pipe connections, hose connections, fittings and adapters upstream of the gas control with approved gas leak detectors. In the event a gas leak is detected, check the components involved for cleanliness and proper application of pipe compound before further tightening. Further tighten the gas connections as necessary to stop the leak. After all connections are checked and any leaks are stopped, turn on the main burner. Stand clear while the main burner ignites to prevent injury caused from hidden leaks that could cause flashback. With the main burner in operation, check all connections, hose connections, fittings and joints as well as the gas control valve inlet and outlet connections with approved gas leak detectors. If a leak is detected, check the components involved for cleanliness in the thread areas and proper application of pipe compound before further tightening. Further tighten the gas connection as necessary to stop the leak. If necessary, replace the parts or components involved if the leak cannot be stopped. Ensure all gas leaks have been identified and repaired before proceeding.



WARNING

Fire and Explosion Hazard

- Do not use open flame (matches, torches, candles, etc.) in checking for gas leaks.
- Use only approved leak detectors.
- Failure to follow this warning can lead to fires or explosions.
- Fires or explosions can lead to property damage, personal injury or loss of life.

8. A qualified service agency must check for proper operating gas pressure upon installation of the heater.
9. Light according to instructions on the heater or within owner's manual.
10. It is extremely important to use the proper size and type of gas supply line to assure proper functioning of the heater. Refer to Standard AG601. Contact your fuel gas supplier for proper line sizing and installation.
11. Make sure the heater is fitted with an approved regulator. A regulator must be connected to the gas supply so that gas pressure at the inlet to the gas valve is regulated within the range specified on the dataplate at all times. Contact your gas supplier, or the L. B. White Co., Inc. if you have any questions.
12. This heater can be configured for use with either L.P. vapor withdrawal or natural gas. Consult the dataplate, located on interior of the burner end or motor end door, for the gas configuration of the

specific heater. Do not use the heater in an L.P. gas liquid withdrawal system or application. If you are in doubt, contact the L. B. White Co., Inc.

13. Eventually, like all electrical/mechanical devices, the thermostat can fail. Thermostat failure may result in either an underheating or overheating condition which may damage critical products and/or cause animal injury or death. Critical products and/or animals should be protected by a separate back-up control system that limits high and low temperatures and also activates appropriate alarms.

14. Take time to understand how to operate and maintain the heater by using this Owner's Manual. Make sure you know how to shut off the gas supply to the building and also to the individual heater. Contact your fuel gas supplier if you have any questions.

15. Any defects found in performing any of the service or maintenance procedures must be eliminated and defective parts replaced immediately. The heater must be retested by properly qualified service personnel before placing the heater back into use.

AIR DIVERTER INSTALLATION INSTRUCTIONS

(Optional accessory on some models.)

(Appearance of the outlet on heater may vary from model to model.)

1. Optional air diverters can be installed in the heater outlet to provide direction to the heated air as it exits the heater. Installation options include installing the diverters in such a way as to broadly distribute the air in two 45 degree paths or to focus the air flow in one 45 degree direction.
2. The air diverter's tabs on each half will "pop" into the blower outlet between the inside of the case assembly and the blower housing outlet. If the notched tabs do not "pop" into the blower outlet, loosen (do not remove) the blower outlet screws. Doing this provides a gap into which you can insert the tabs. Retighten the screws after installation.

FIG. 1 (Typical installation allowing two directions of air movement.)

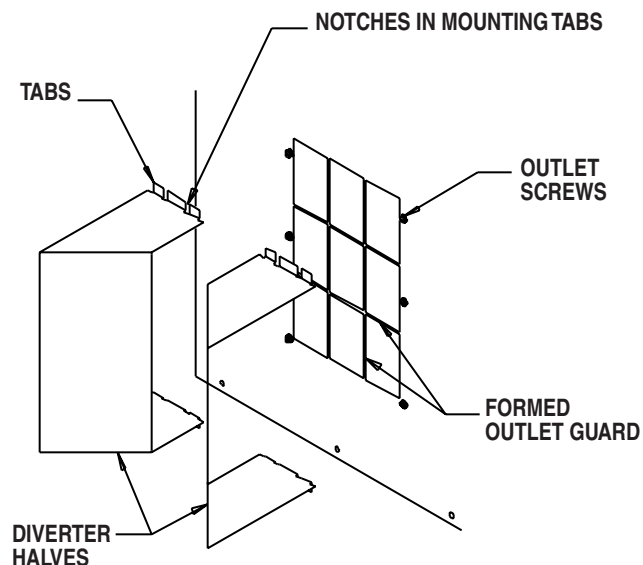

Alternate Air Diverter Installations



HANGING INSTRUCTIONS

1. Assemble according to the illustration below and tighten all eyebolts securely.

FIG. 2

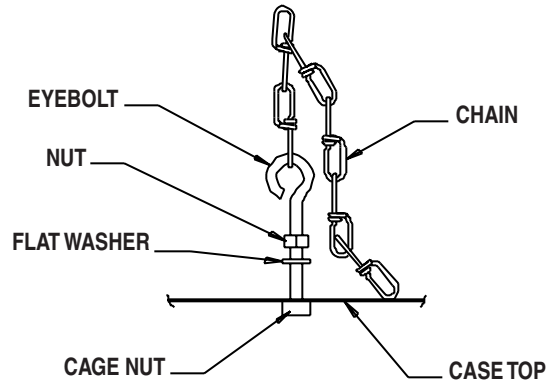

2. Be sure heater is securely fastened and is hanging level. (Check crosswise and lengthwise.)
4. See Fig. 3 for **typical** indoor installation. In any animal confinement building, consideration must be given to making sure the heater is located away from the livestock so that livestock cannot knock the heater, tear it loose from its mounting, or damage the heater or its gas supply line in any way. Make sure you observe and obey minimum clearance distances to combustible materials as stated in the specification section of this owner's manual and on the heater dataplate.

FIG. 3

NOTE: REGULATORS SHOULD ALWAYS BE MOUNTED OUTDOORS. IF CIRCUMSTANCES FORCE INSTALLING THE REGULATOR INDOORS, THE REGULATOR'S VENT MUST BE VENTED OUTDOORS USING VENT LINE NO SMALLER THAN VENT OPENING.

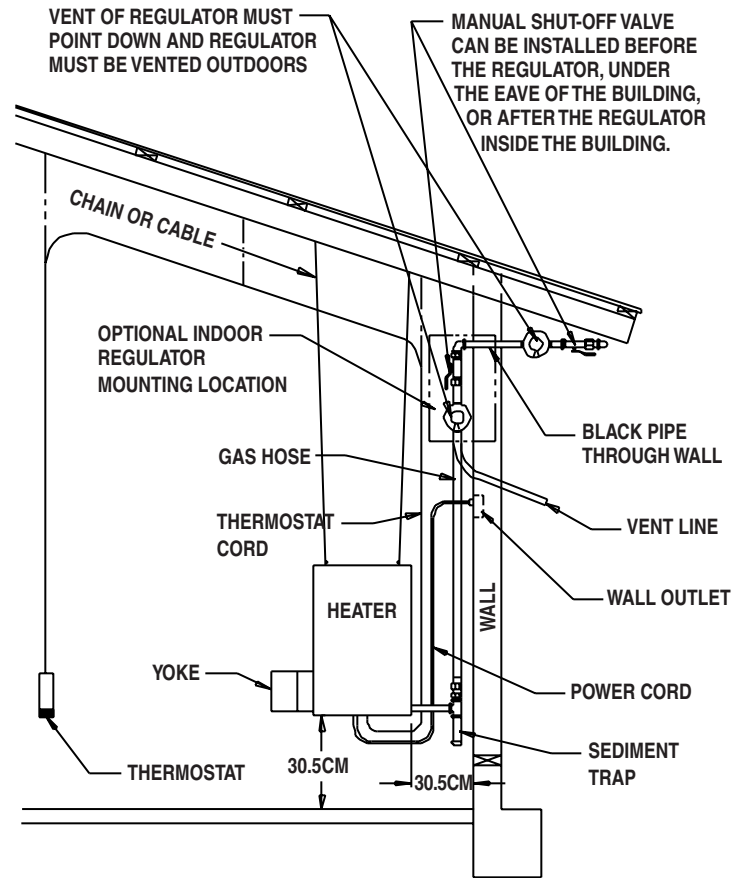

SEDIMENT TRAP ASSEMBLY

Assemble the tee, nipples and cap together and tighten securely. The sediment trap assembly must always be mounted in a vertical position. Make sure pipe thread compound that is resistant to both L.P. and natural gas is used in making all connections. **Check all connections for gas leaks using approved gas leak detectors.**

FIG. 4

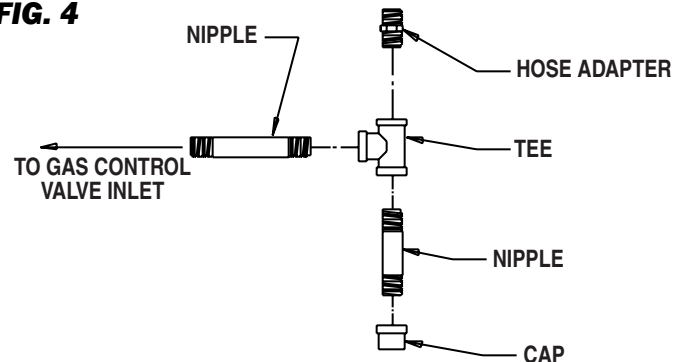

THERMOSTAT INSTALLATION

WARNING
Electrical Shock Hazard

- Disconnect the electrical supply before connecting the thermostat to the heater.
- Failure to follow this warning can result in electrical shock, leading to personal injury or death.

1. To Connect the Series Tap Plug Thermostat Kit:

- a. Connect the power cord of the heater to the female side of the plug on the end of the thermostat cord.
- b. Plug the male side of the series tap plug on the thermostat cord into a three-wire (grounded) electrical outlet within the building.

2. To Connect the Direct Wired Thermostat Kit to the Control Box on the Heater:

- a. The installation and wiring of a thermostat must be done by an electrician or someone properly qualified.
- b. The thermostat may use 18 gauge, 3 wire cord to handle the voltage being supplied to the thermostat.
- c. Follow all instructions provided with the thermostat kit.
- d. The heater must be tested for proper operation after the thermostat has been connected.

MANUAL SHUT-OFF VALVE, HOSE AND REGULATOR ASSEMBLY

1. Always use approved pipe thread compound suitable for use with L.P. or natural gas on the threaded connections.
2. Assemble the components together according to the figure. This view is to show general assembly of the components only. The regulator must always be mounted so its vent, regardless of location on the regulator, is always pointed downward.
3. Tighten all connections securely.
4. Check all connections for gas leaks using approved gas leak detectors.

FIG. 5

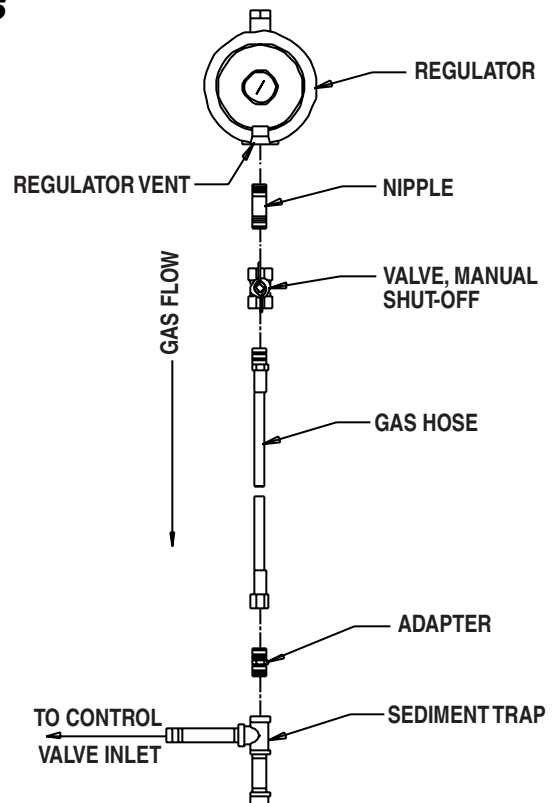

Start-Up Instructions

Follow steps 1 - 7 on initial start-up after heater installation by a qualified gas heater service person. For normal start-up, simply turn thermostat above room temperature. The heater will start.

1. Open all manual fuel supply valves and check for gas leaks using approved leak detectors.
2. Remove the cover from the gas control valve enclosure.
3. The gas control valve incorporates a manual gas shut off feature. Position the indicator on the shut off knob to "pilot". Fully depress the red pilot button located on the control valve while applying flame to the pilot light. Keep the button depressed for about 30 seconds to allow the thermocouple to warm up so the pilot stays lit after you release the pilot button.
4. Once the pilot stays lit, position the knob to "on". Reinstall the metal cover.

ATTENTION

On new installations it may take a short period of time for the gas to purge out any air in the pilot line before the pilot stays lit.

5. Connect the electrical cord to an approved electrical outlet.
6. Set the thermostat to a point above room temperature. The heater will light. Turn the thermostat to desired setting.
7. Do not exceed the input rating stamped on the dataplate of the heater. Do not exceed the burner manifold pressure stated on the dataplate. Do not use an orifice size different than specified for the specific input rating of this heater, fuel type configuration and altitude.

FIG. 6

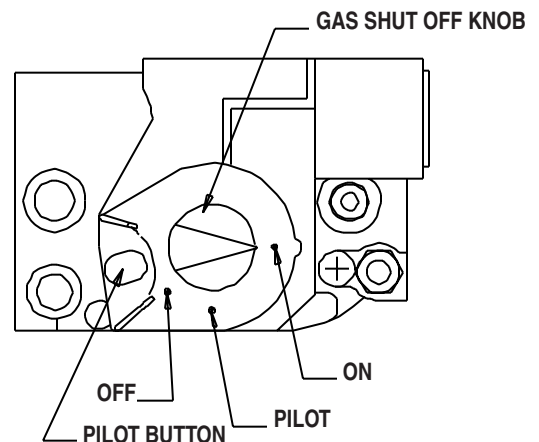

Shut-Down Instructions

If the heater is to be shut down for cleaning, maintenance or repair, follow steps 1 - 5. Otherwise, simply turn thermostat to "off" or "no heat" for standard shut down.

1. Close all manual fuel supply valves.
2. With the heater lit, allow heater to burn off excess fuel in gas supply hose.

3. Position the knob on the control valve to the "off" position.
4. Turn thermostat to "off" or "no heat" position.
5. Disconnect the heater from the electrical supply.

Cleaning Instructions



WARNING Fire, Burn, and Explosion Hazard

- This heater contains electrical and mechanical components in the gas management, safety and airflow systems.
- Such components may become inoperative or fail due to dust, dirt, wear, aging, or the corrosive atmosphere of an animal confinement building.
- Periodic cleaning and inspection as well as proper maintenance are essential to avoid serious injury or property damage.

1. Before cleaning, shut off all gas supply valves and disconnect the electrical supply.
2. The heater should have dirt or dust removed periodically:
 - a. After each flock or between building re-population, give the heater a general cleaning using compressed air or a soft brush on its interior and exterior. At this time, dust off the motor case to prevent the motor from over-heating and shutting the heater down.
 - b. At least once a year, give the heater a thorough cleaning. At this time, remove the fan and motor assembly and brush or blow off the fan wheel, giving attention to the individual fan blades. Make sure the burner air inlet venturi ports and the “throat” of the casting are free of dust accumulation and the area between the heat chamber top and inside case is also free of dust.
 - c. When washing with water, observe and obey the Warning within these Cleaning Instructions. This same Warning is also supplied on the heater.



WARNING

This heater may be washed only on the external case assembly provided:

- A. The heater is disconnected from the electrical supply.
- B. All access panels are securely closed.
- C. Water spray nozzle shall not discharge within 1.83 m of the heater.
- D. The water pressure does not exceed 310 KPa for 10 seconds on each side of heater.
- E. The heater is not reconnected to electrical supply for a minimum of 1 hour or until the heater is thoroughly dry.

Improper cleaning of the heater can cause severe personal injury or property damage due to water and/or cleaning solution:

1. In electrical components, connections and wires causing electrical shock or component failure.
2. On gas control components causing corrosion which can result in gas leaks and fire or explosion from the leak.

Clean internal components of the heater with a soft, dry brush or cloth, or compressed air.

Maintenance Instructions

1. Have your gas supplier check all gas piping annually for leaks or restrictions in gas lines. Also, at this time have your gas supplier clean out the sediment trap of any debris that may have accumulated.
2. **The appliance area shall be kept clear and free from combustible materials, gasoline, and other flammable vapors and liquids.**
3. Regulators can wear out and function improperly. Have your gas supplier check the date codes on all regulators installed and check delivery pressures to the appliance to make sure that the regulator is reliable.
4. Regulators must be periodically inspected to make sure the regulator vents are not blocked. Debris, insects, insect nests, snow, or ice on a regulator can block vents and cause excess pressure at the appliance.

Service Instructions

MOTOR AND FAN WHEEL ASSEMBLY

1. Shut off the gas supply to the heater.
2. Disconnect the heater from its electrical supply.
3. Open the case fan access panel on the control box end of the heater.
4. Disconnect the motor leads.
5. Remove the screws securing the motor mounting plate to the fan housing.
6. Pull the fan and motor assembly from the housing.
7. Loosen the square head set screw(s) on the fan wheel with a wrench.
8. Pull the fan wheel from the motor shaft. Use a wheel puller if necessary.
9. Remove the four (4) nuts securing the motor to the mounting plate.
10. To replace the motor and fan, reverse the above procedures.

NOTES: a. Fan wheel to motor mount plate spacing must be adjusted to 3.2 mm clearance before tightening the fan wheel to the motor shaft.

b. Make sure that set screw(s) of the fan are on the “flats” of motor shaft when tightening.

FIG. 7

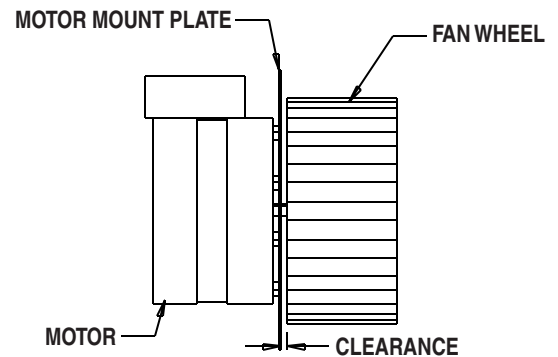

SAIL SWITCH AND SAIL (FLAPPER)

1. Shut off the gas supply to the heater.
2. Disconnect the heater from its electrical supply.
3. Make sure there is not any dust, dirt, etc. that will cause “binding” on the pivot points of the sail as it rides within the blower housing. If debris is found, use a soft brush or compressed air to clean the area as necessary.
4. The “arm” of the sail should engage the arm of the sail switch when the trailing edge of the sail body is lifted and is approximately 31.7 mm to 34.9 mm off the blower housing bottom. At this distance you will hear a “click” which are the contacts closing within the switch mechanism.
5. If the switch contacts do not close within this distance, then manually push in the arm in the switch to make sure the switch is not defective. If a “click” is heard, the switch is good and the sail arm then needs to be adjusted to engage the switch arm.

6. Using a needle nose pliers, gently bend up the arm of the sail (**NOT THE SWITCH ARM**) in increments until the sail arm engages the switch arm, closing the contacts of the switch when the sail body trailing edge is 31.7 mm to 34.9 mm from the housing bottom.

FIG. 8

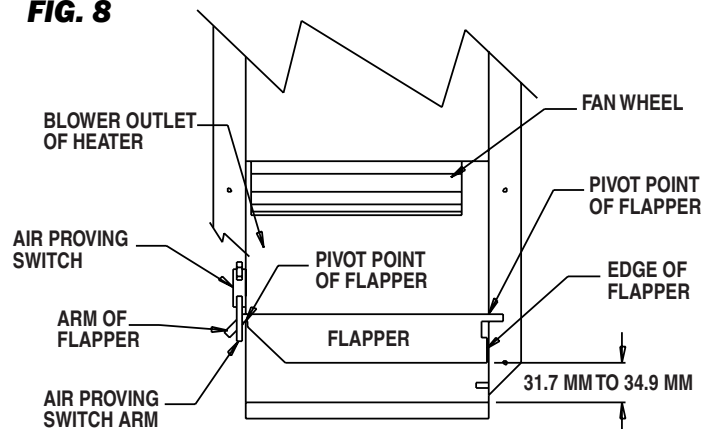

PILOT LIGHT ASSEMBLY

IMPORTANT – Natural Gas Models

When performing any pilot assembly servicing, make sure you don't tear or destroy the foil face fiber gasket located between pilot bracket and burner casting face. Doing so will cause pilot outages. Always make sure that if you must remove it for cleaning the burner area that it is replaced and properly positioned.

1. Shut off the gas supply to heater.
2. Disconnect the heater from its electrical supply.
3. Let the appliance cool down so the pilot assembly is cool to touch.
4. Loosen the wing screw at the pilot assembly by turning counterclockwise. (It is not necessary to remove the screw entirely from the pilot assembly. You need to loosen it just enough to allow you to remove the pilot shield.)
5. When loosened, pull up on the pilot shield, exposing the pilot bracket, pilot orifice, and thermocouple.
6. Using a soft brush or compressed air, clean the pilot stack (pop-riveted on inside of pilot shield), of dust and dirt, paying attention to the throat of the pilot stack and the flame spreader at the top of the stack.
7. Brush off the top of the pointed pilot orifice making sure dust and dirt have not plugged orifice hole. If the orifice must be removed, use the appropriate size wrench to loosen and remove the compression fitting and pilot tube from the inlet of the pilot orifice. Use a wrench to loosen and remove the pilot orifice from the pilot bracket. Hold the orifice up to the light to see if the hole in the orifice is clear and open. If not, blow out with compressed air.
8. To replace the shield and the pilot orifice, reverse above procedure.
9. Check for gas leaks.

IMPORTANT

- The hole in the pilot orifice is drilled to a specific diameter to match the fuel and gas pressure being used. Do not poke or push sharp instruments into the hole. Doing so will enlarge the hole, creating pilot light outage problems. Clean the orifice only with compressed air, a soft brush, or a dry rag. If necessary, replace the pilot orifice.
- Do not use a pliers to remove the pilot orifice. Pliers will "round off" the the hex head nut on the base of the orifice, creating difficulty in servicing at a later time. Only use a wrench of appropriate size.

FIG. 9

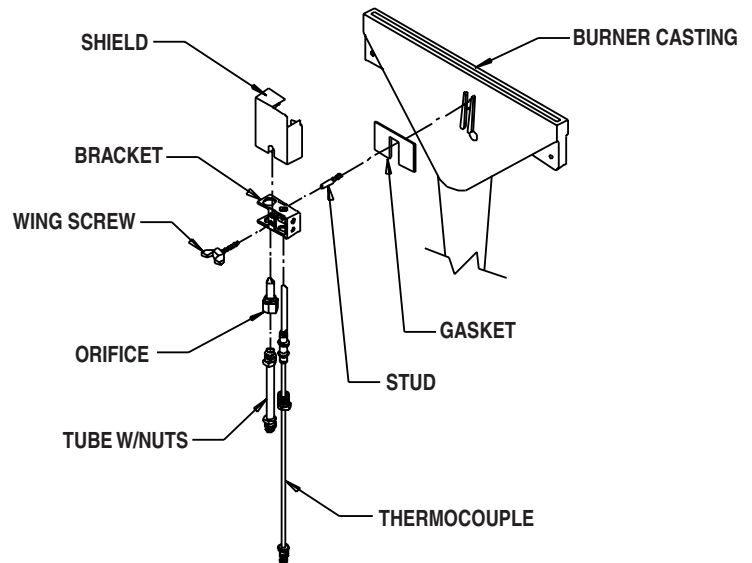

1. Shut off the gas supply to heater.
2. Disconnect the heater from its electrical supply.
3. Let the appliance cool down so pilot assembly is cool to touch.
4. Loosen wing screw at pilot assembly by turning counterclockwise. It is not necessary to remove the screw entirely from the pilot assembly. You need to loosen it just enough to allow you to remove the pilot shield.
5. When loosened, pull up on the pilot shield, thereby exposing the pilot bracket, pilot orifice, and thermocouple.
6. To remove the thermocouple, loosen the attachment nut (turn counterclockwise) until the nut is entirely out of the pilot bracket. Remove the thermocouple from the pilot bracket.
7. Remove the lead connector nut threaded into the power unit on the gas control valve.
8. To assemble, reverse above procedure.

IMPORTANT

- The thermocouple is an important safety device which works directly with the pilot safety control valve. It should only be replaced with L.B. White part number 120-21196.
- When threading the thermocouple's connector nut back into the power unit on the gas control valve, thread the nut in "finger tight" and "snug it" in place with a wrench. **DO NOT OVERTIGHTEN OR USE UNNECESSARY FORCE ON THE NUT WHEN TIGHTENING.** Doing so will destroy the power unit in the gas control valve.
- Do not use a pliers when removing or replacing thermocouple attachment nut or connector nut. Doing so will round off the hex nuts, making servicing difficult later on. Always use the appropriate size wrench.

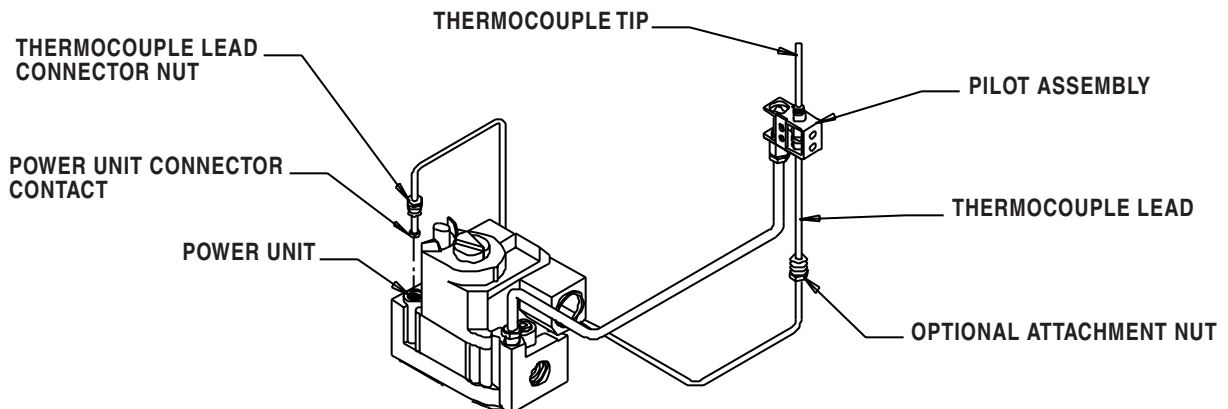
FIG. 10

GAS CONTROL VALVE

WARNING
Fire and Explosion Hazard

- Do not disassemble the gas control valve.
- Do not attempt to replace any components on the gas control valve.
- The gas control valve must be replaced if any physical damage occurs to the control valve assembly.
- Failure to follow this warning will result in fire or explosions, leading to injury or death to humans and livestock, and building damage.

1. Brush off any accumulation of dust that may be found.
2. Check manifold gas pressure with a low pressure gas gauge:
 - a. Shut off the gas supply to the heater.
 - b. Disconnect the heater from its electrical supply.
 - c. Remove the metal cover from the control valve enclosure.
 - d. Turn the screw in the pressure tap at the outlet of the valve counterclockwise a minimum of one full turn.
 - e. Connect a low pressure gas gauge to the pressure tap.
 - f. Open fuel supply and reconnect heater to electric supply.

g. When heater lights, the gas gauge will read 2.50 KPa - LP or .75 KPa - Natural gas pressure. This pressure is the flowing gas pressure necessary for the heater to deliver maximum output. If the gauge does not indicate proper manifold pressure, check inlet pressure to the gas control valve. Maximum and minimum acceptable inlet pressures to gas control valve are shown in the heater specifications table (See page 4.) and on the heater's dataplate. The inlet pressure may need adjustment as necessary to achieve proper manifold pressure. Inlet pressure is checked in the same manner as outlet pressure.

h. After pressures have been checked, shut off the gas supply and electrical supply to the heater, remove the gauge, and tighten the pressure tap securely. Open gas supply and reconnect the heater to its electrical supply.

3. Reinstall the metal cover.

FIG. 11

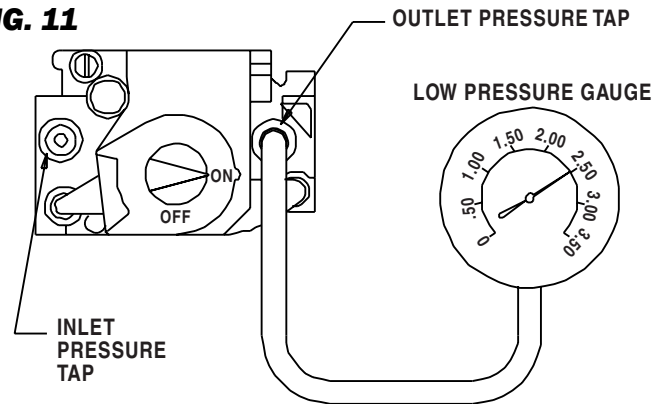

TESTING THE MANUAL RESET HIGH LIMIT SWITCH

WARNING
Fire Hazard

- Do not operate the appliance with the high limit switch bypassed.
- Operating the heater bypassed high limit switch may lead to overheating, possibly resulting in a fire, with subsequent damage to the heater, building damage, or loss of livestock.

The high limit switch should be tested a minimum of once per year when the heater is given a thorough cleaning.

1. Disconnect the heater from its electrical supply.
2. Remove the high limit switch from the heat chamber.
3. Holding the switch by one of its mounting legs or electrical terminals, apply a small flame only to the sensing surface on the back of the switch. **Be careful not to melt the plastic housing of the switch when conducting this test.**
4. Within a minute, you should hear a "pop" coming from the switch, which indicates the contacts of the switch have opened.

5. Allow the switch cool down for about a minute before firmly pressing the red reset button on the switch.
6. Check for electrical continuity across the switch terminals to make sure the contacts have closed.
7. Reinstall the switch back into the heater. Reconnect the heater to its electrical supply. Start the heater and check for proper operation.

FIG. 12

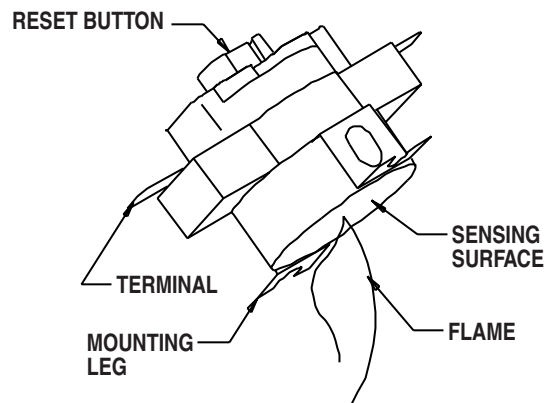

Troubleshooting Guide

READ THIS ENTIRE SECTION BEFORE BEGINNING TO TROUBLESHOOT PROBLEMS.

The following troubleshooting guide provides systematic procedures for isolating equipment problems. This guide is intended for use by a QUALIFIED GAS HEATER SERVICE PERSON. **DO NOT ATTEMPT TO SERVICE THESE HEATERS UNLESS YOU HAVE BEEN PROPERLY TRAINED.**

TEST EQUIPMENT REQUIRED

The following pieces of test equipment will be required to troubleshoot this system with minimal time and effort.

- **Digital Multimeter** - for measuring AC and DC voltage and resistance.
- **Thermocouple Diagnostic Kit** - (L. B. White Part No. 550-08506) When used with a standard digital multimeter, this kit allows testing of the thermocouple and electromagnetic power unit strength of the pilot safety gas control valves.
- **Low Pressure Gauge** - for checking inlet and manifold pressures at the gas control valve against nameplate rating.



WARNING

Electrical Shock and Burn Hazard

- Troubleshooting this system may require operating the unit with line voltage present and gas on. Use extreme caution when working on the heater.
- Failure to follow this warning may result in property damage, personal injury or death.
- Visually inspect equipment for apparent damage.
- Check all hoses for abrasion and wear. Replace any that are suspect.
- Make sure heater is properly installed and meets minimum clearances to nearest combustible materials. (Refer to dataplate on heater.)
- Check all wiring for loose connections and worn insulation.

To effectively use these flow charts, you must first identify the problem. The problems are numbered sequentially, along with a brief explanation of each problem. Start at the “diamond” closest to the identified problem and proceed with each step, performing whatever tests are suggested. After each step or test, the guide will direct the service person to the next logical step based on the outcome of the previous check.

Components should be replaced only after each step has been completed and replacement is suggested in the flow chart.

The problems are listed below along with the page number on which you may find the flow chart for the specific problem.

<u>Problem</u>	<u>Description</u>	<u>Page</u>
1	Pilot will not light	19
2	Pilot will not stay lit when pilot control button is released	20
3	Motor runs. Burner does not light with pilot light lit	21
4	Motor does not run, heater does not light with pilot light lit	22
5	Main burner cycles on and off repetitively. Pilot stays lit	23
6	Pilot will not stay lit when main burner and blower are operating	23
7	High limit switch is open	24
8	Burner does not shut off	25
9	Flame “lifting” off of burner.....	25
10	Burner flame drops out after 10 - 15 minutes of operation	25
11	Gas control valve “chatters”	26
12	Motor “hums”	26

Problem 1

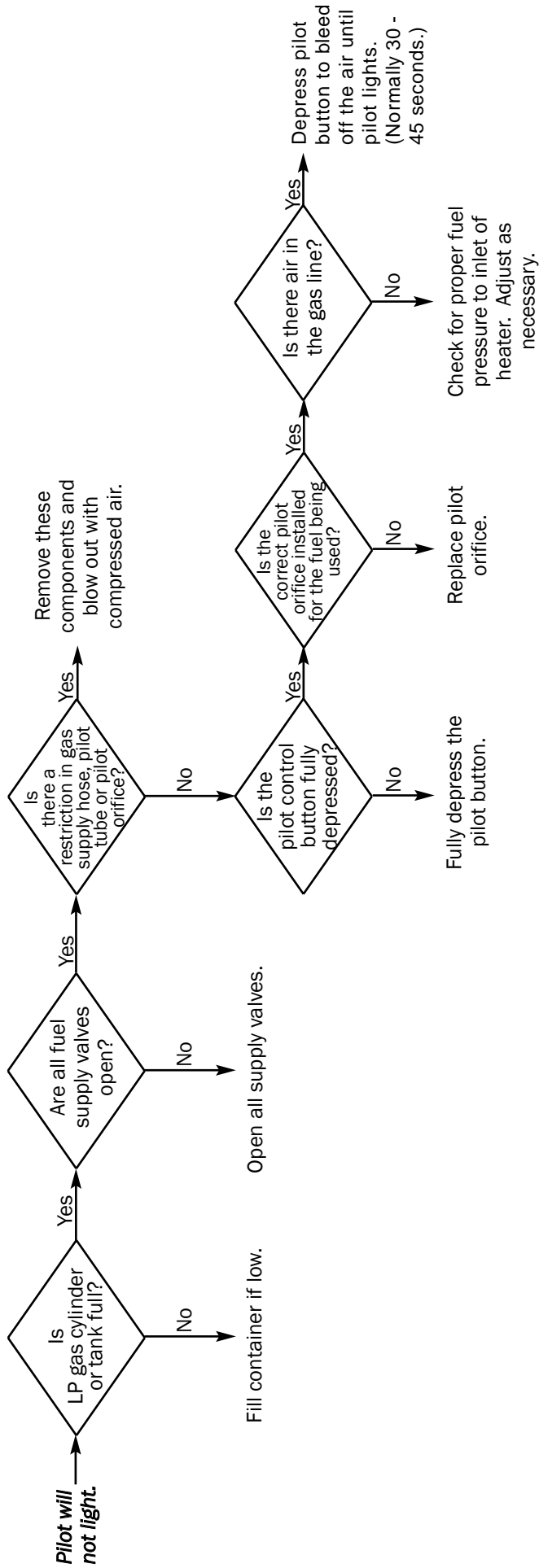

Problem 2

Pilot will not stay lit when pilot control button is released.

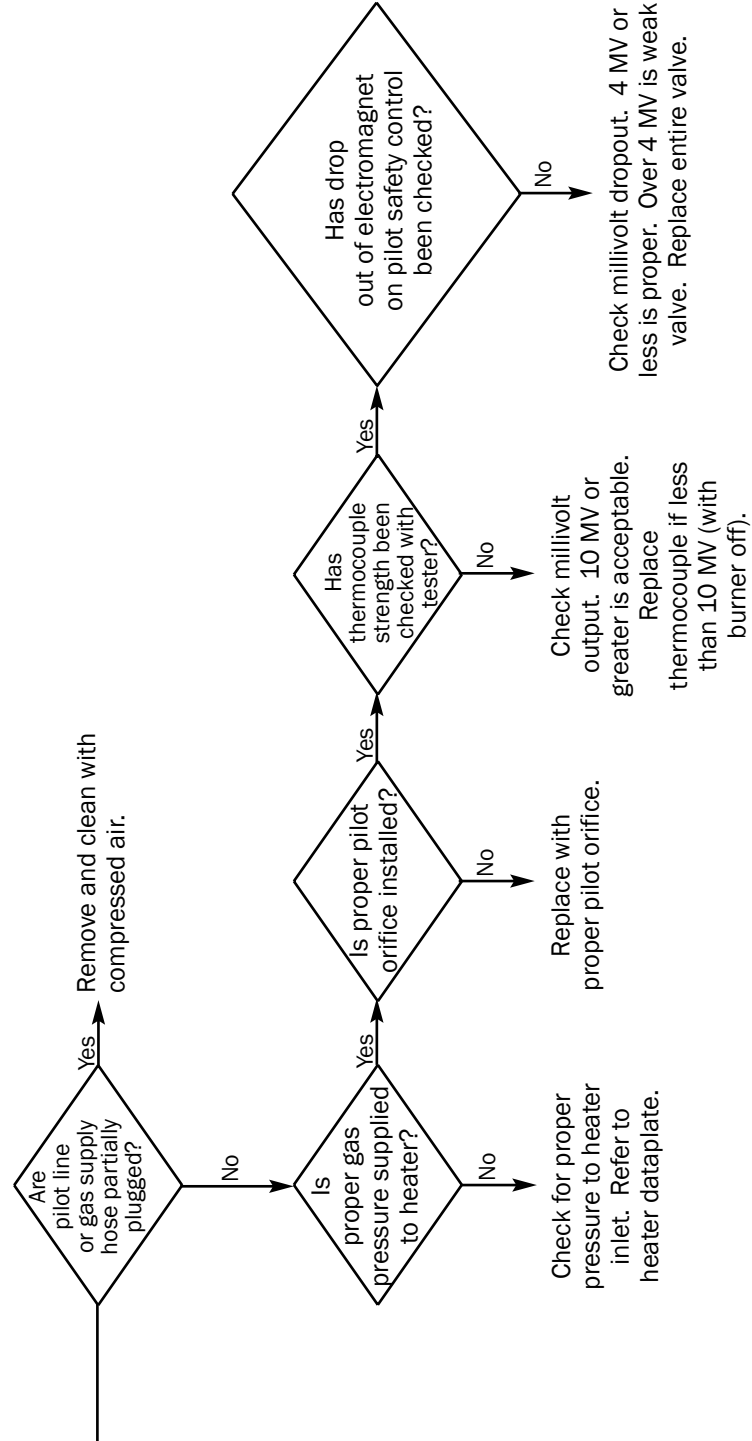
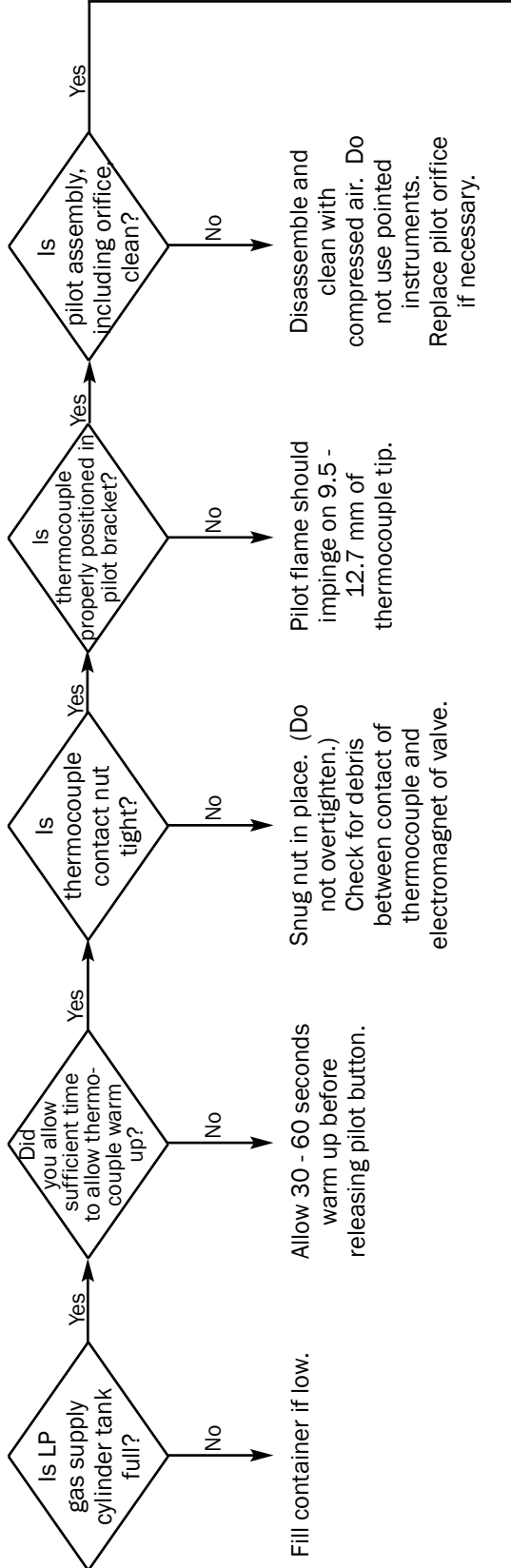

Problem 3

**Motor runs.
Burner
does not
light with
pilot light
lit.**

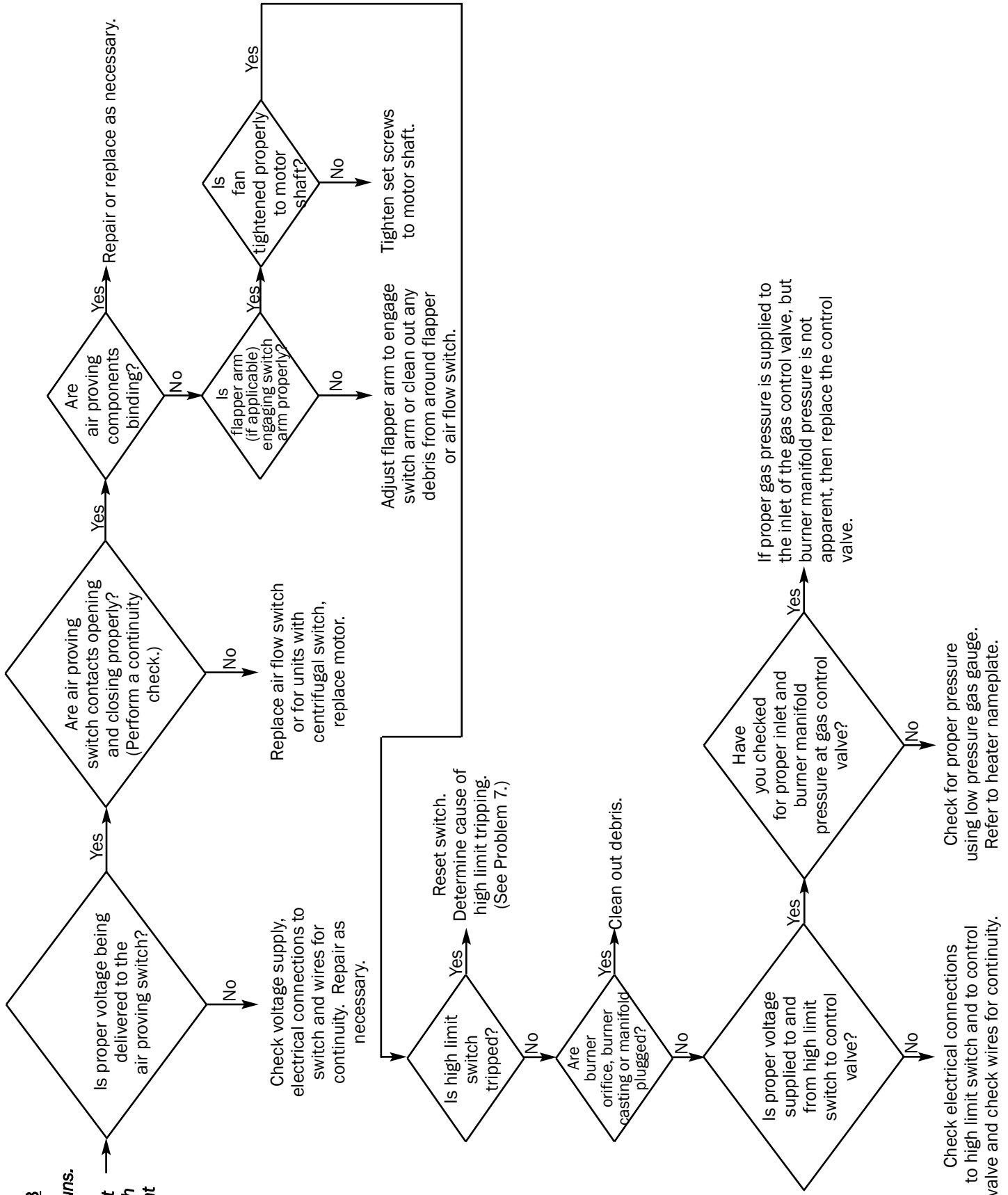

Problem 4

Motor does not run, heater does not light with pilot light lit.

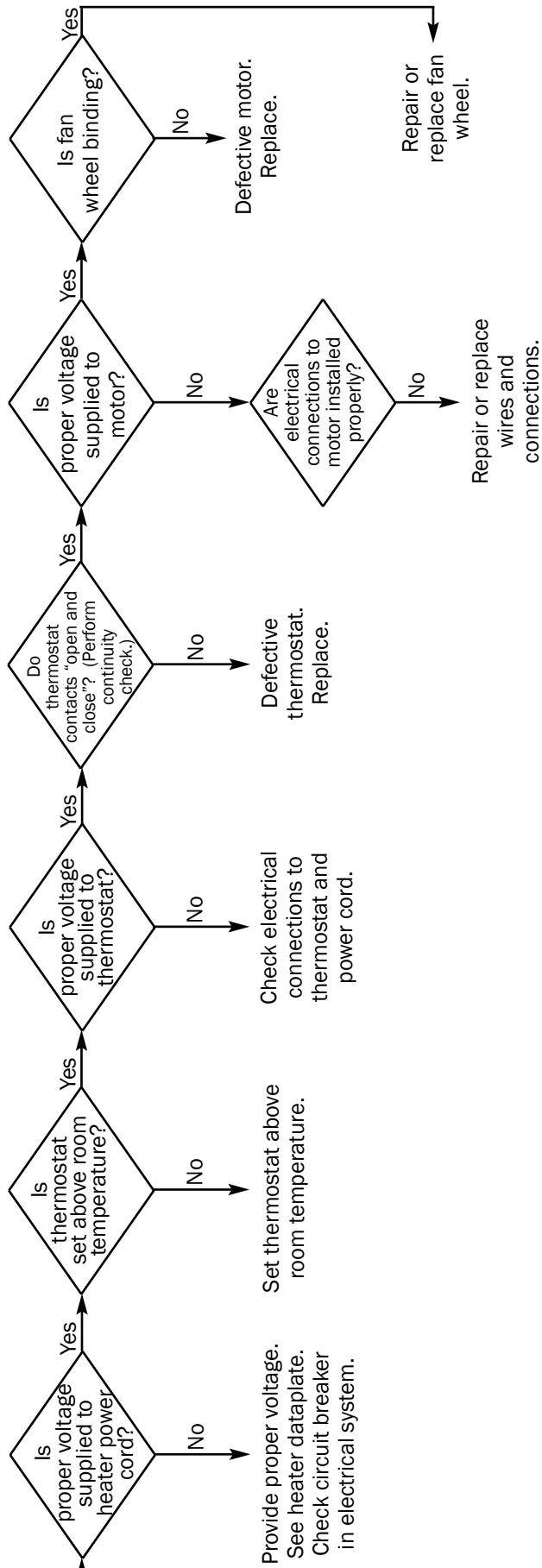

Problem 5

Main burner cycles on and off repetitively. Pilot stays lit.

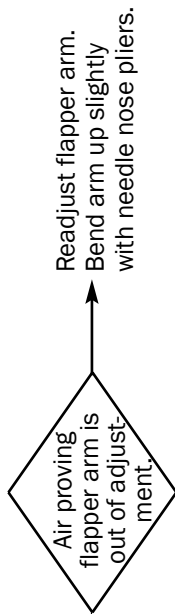

Problem 6

Pilot light will not stay lit when main burner and blower are operating.

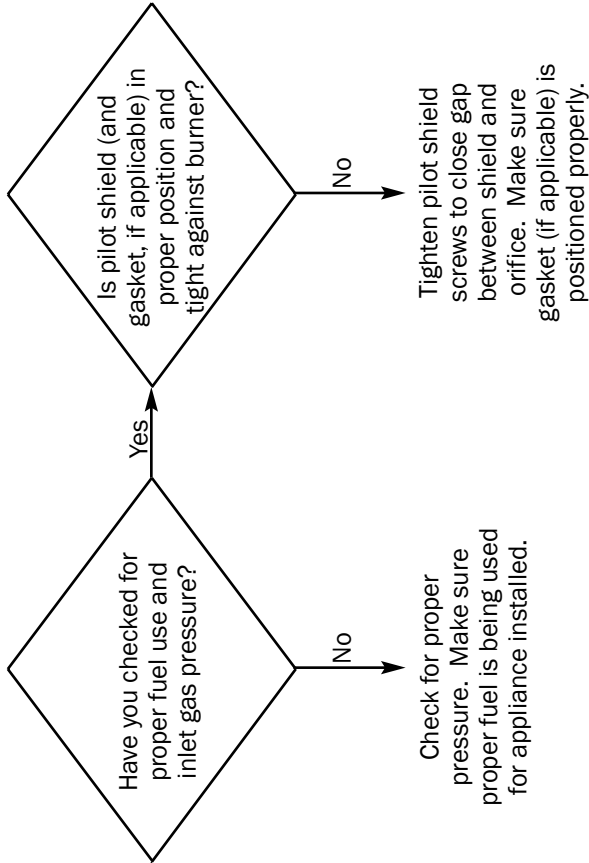

Problem 7

High limit switch is open.

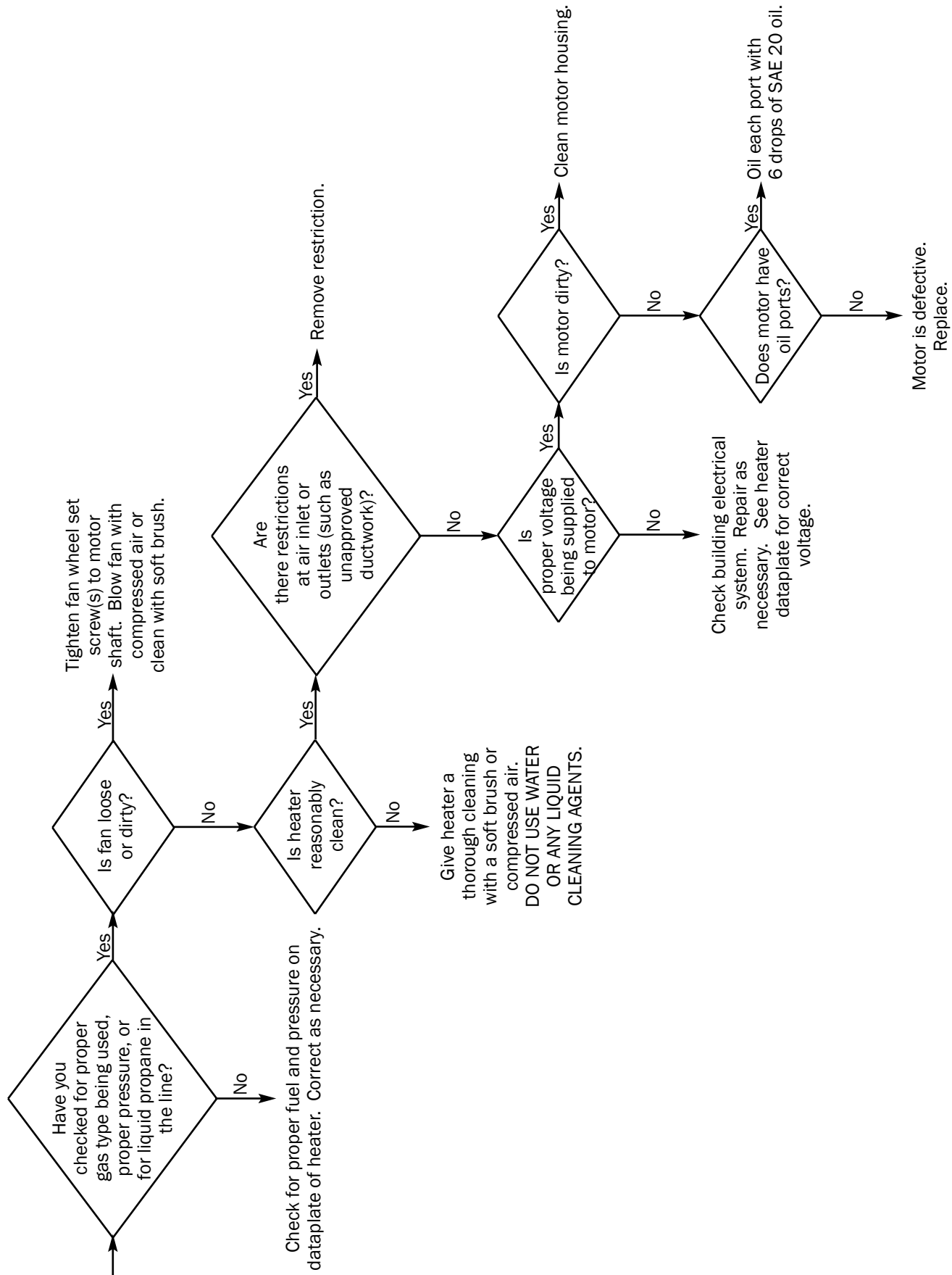

Problem 8

Burner does not shut off when temperature requirement is satisfied.

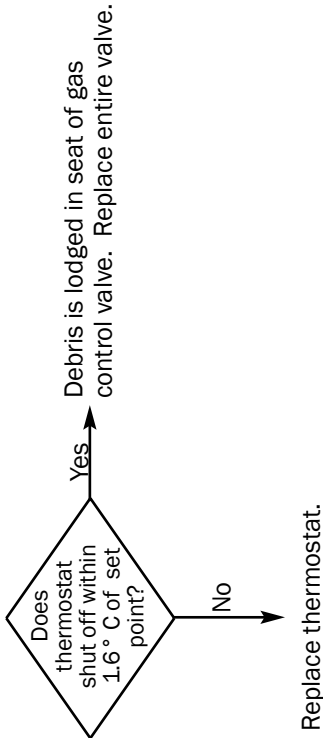

Problem 9

Flame "lifting" off of burner.

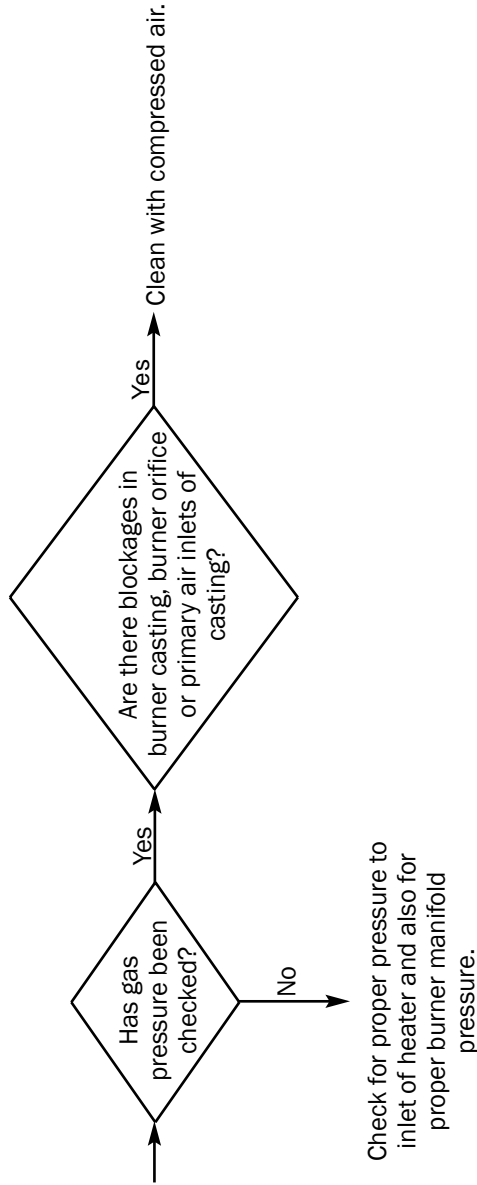

Problem 10

Burner flame drops out after 10 - 15 minutes of operation.

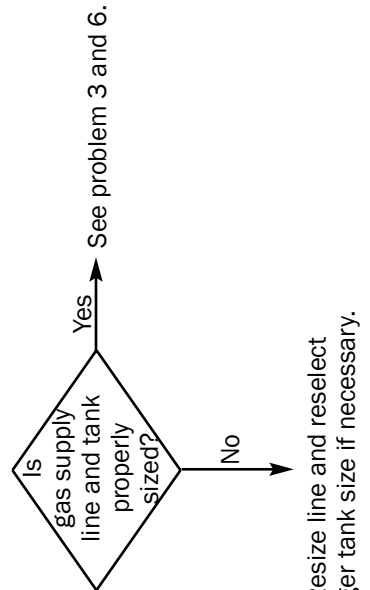

Problem 11

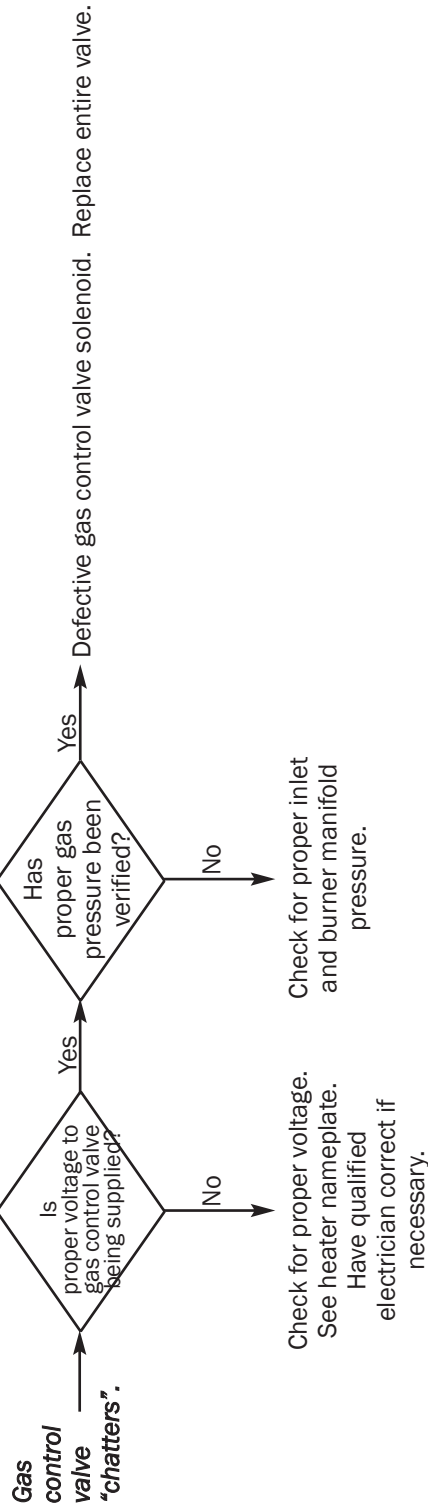

Problem 12

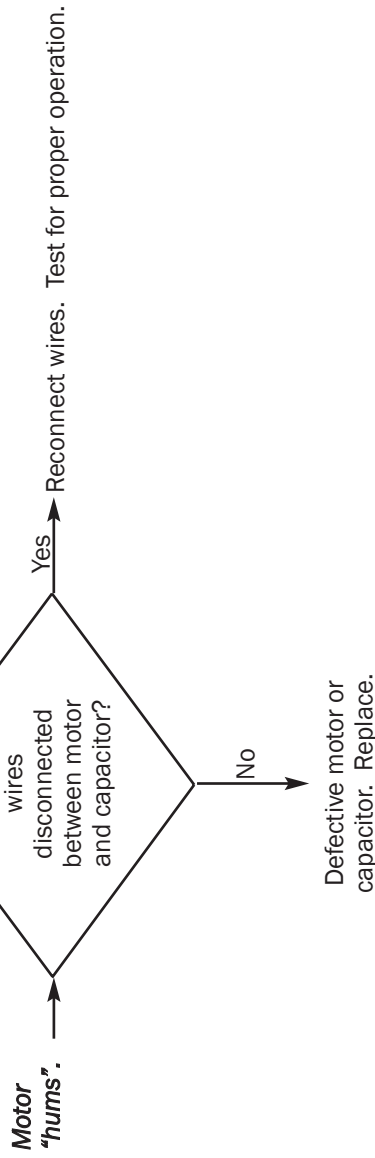

- (1) Some thermocouples use a retainer clip to secure the thermocouple into the pilot bracket. Make sure the thermocouple is pushed up completely into the hole so clip on thermocouple holds it securely within the bracket. Other thermocouples use a retainer nut to hold the thermocouples in place. Make sure the nut is securely tightened.
- (2) With any electrical problem, all wiring should be checked for good connections and proper voltage and repaired if a problem is found.
- (3) To determine if part is defective, place a jumper wire across the two terminals that the wires are connected to. Use the jumper wire only to determine if part is defective. Replace the part IMMEDIATELY or do not operate the heater until it has been properly repaired. **NEVER** operate a heater with safety device bypassed.
- (4) The high-limit switch will open or "trip" for a variety of reasons including high fuel pressure (see dataplate or owner's manual for proper pressures) or reduced air flow. Reduced air flow is normally due to intake air obstructions, low voltage or dirty fan wheels, etc.

Electrical Connection and Ladder Diagram

CAUTION

Always refer to the heater's electrical connection diagram when servicing to avoid wiring errors and heater malfunction. Check for proper operation after servicing.

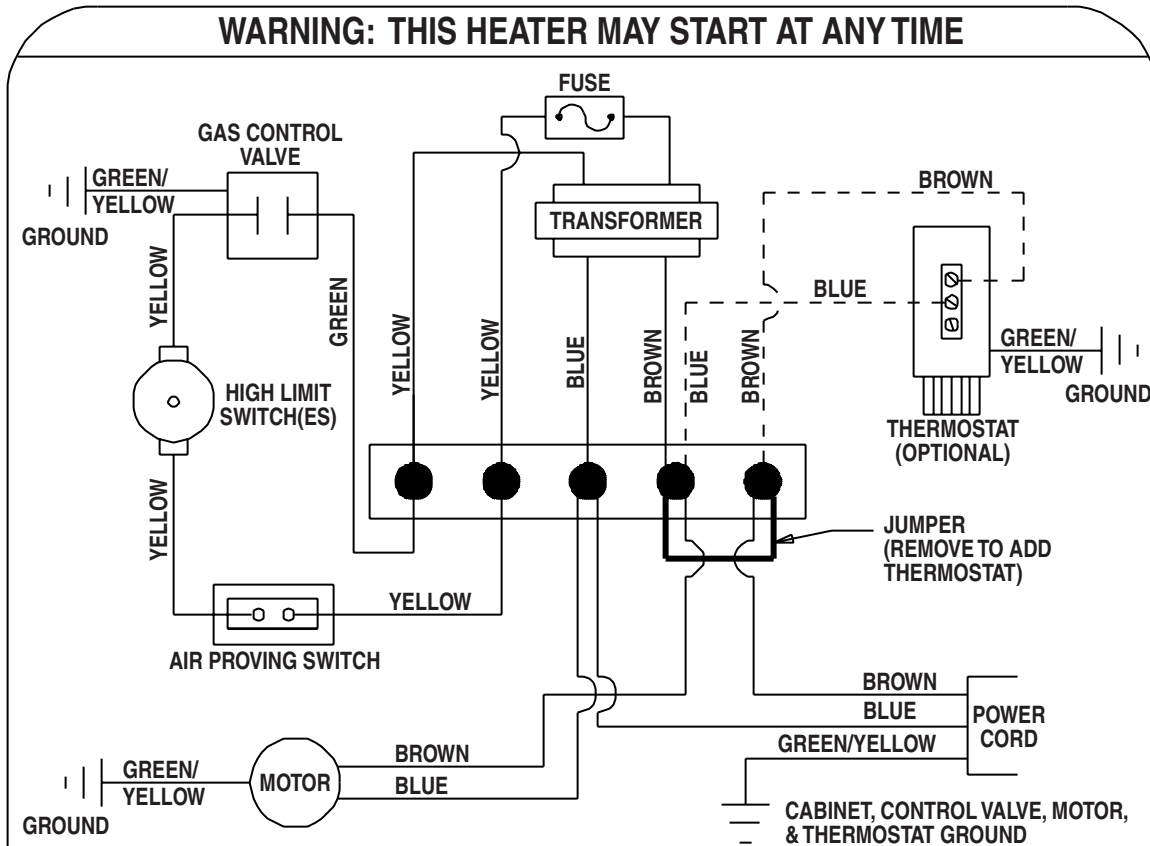

ELECTRICAL CONNECTION DIAGRAM

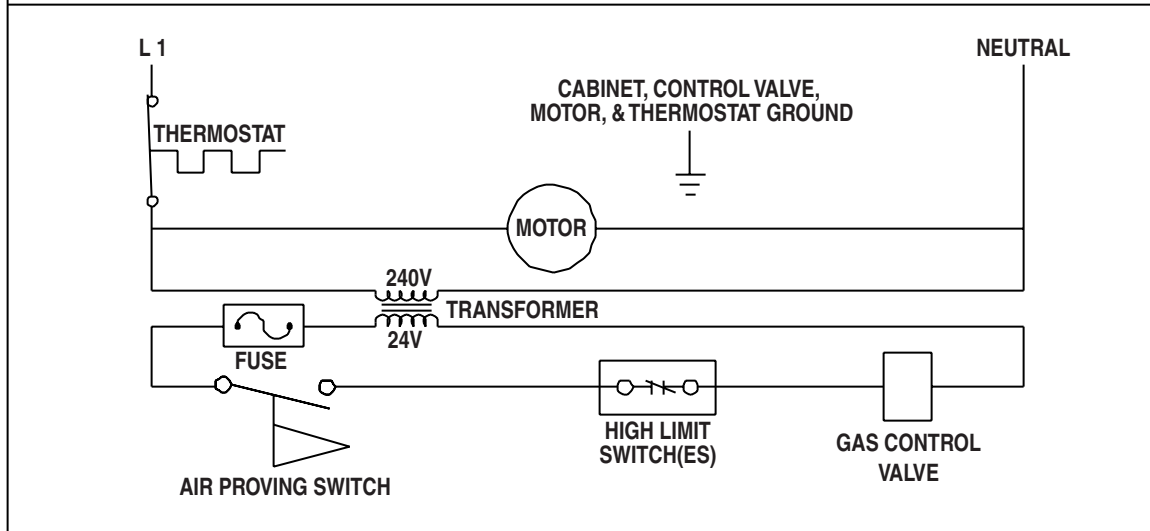

ELECTRICAL LADDER DIAGRAM

IF ANY OF THE ORIGINAL WIRE AS SUPPLIED WITH THE APPLIANCE MUST BE REPLACED, IT MUST BE REPLACED WITH WIRING HAVING A TEMPERATURE RATING OF AT LEAST 302° F (150° C).

Heater Component Function

Air Proving Switch

Safety device used to insure that the proper air flow is being achieved before the gas valve is opened.

Burner

Cast iron component used to channel gas and provide an area at which the fuel may ignite.

Burner Orifice

Brass metering device used to feed gas to burner at a specific rate.

Fan Housing

Chamber used for compressing air for efficient air movement.

Fan Wheel

Component used in conjunction with the motor and fan housing to pull the hot air from heater and blow it into room for heating (also known as a “squirrel cage”).

Gas Hose

Flexible connector used to convey gas from supply line in building to heater.

Heat Chamber

Metal “fire box” within the appliance that provides an area where burner flame mixes with combustion air thereby providing heat.

High Limit Switch

Safety device wired into the control system which is used to break an electrical circuit to the gas control valve in event of overheat situation.

Motor

Electric device used to force preheated air through the heater and to circulate heat within a certain area. Converts electrical energy into mechanical energy.

Pilot Light Orifice

A metering device used to supply gas for the dual purpose of igniting the main burner and heating the thermocouple.

Pilot Safety Control Valve

A gas control valve which is held open by electrical power supplied by a pilot generator and which closes automatically to shut off the flow of gas to the main burner when the pilot flame is extinguished or becomes too small to light the main burner.

Pilot Shield

A formed sheet metal piece that fits around the pilot assembly to protect the the pilot flame against drafts.

Pilot Tube

Formed copper tube used to convey gas from the safety control valve to the pilot light orifice. The tube is internally “tinned” when natural gas is used to resist the effects of sulphur in the fuel.

Regulator

The heart of any gas supply installation. Used to deliver a working pressure to the appliance under varying conditions in tank pressure.

Sail (Flapper)

A formed piece of stainless steel located in the blower outlet of the heater that pivots up with an increase in air pressure, thereby engaging air flow switch.

Thermocouple

A thermoelectric device that converts heat energy directly into electrical energy. Works in conjunction with the electromagnet in the gas control valve thereby providing gas supply for the pilot light.

Thermostat

Electrical device used as an automatic “on/off” switch which will respond to changes in temperature in a certain area. Can be wired so contacts in the thermostat open or close on temperature increase or decrease.

Parts Identification

PARTS SCHEMATIC

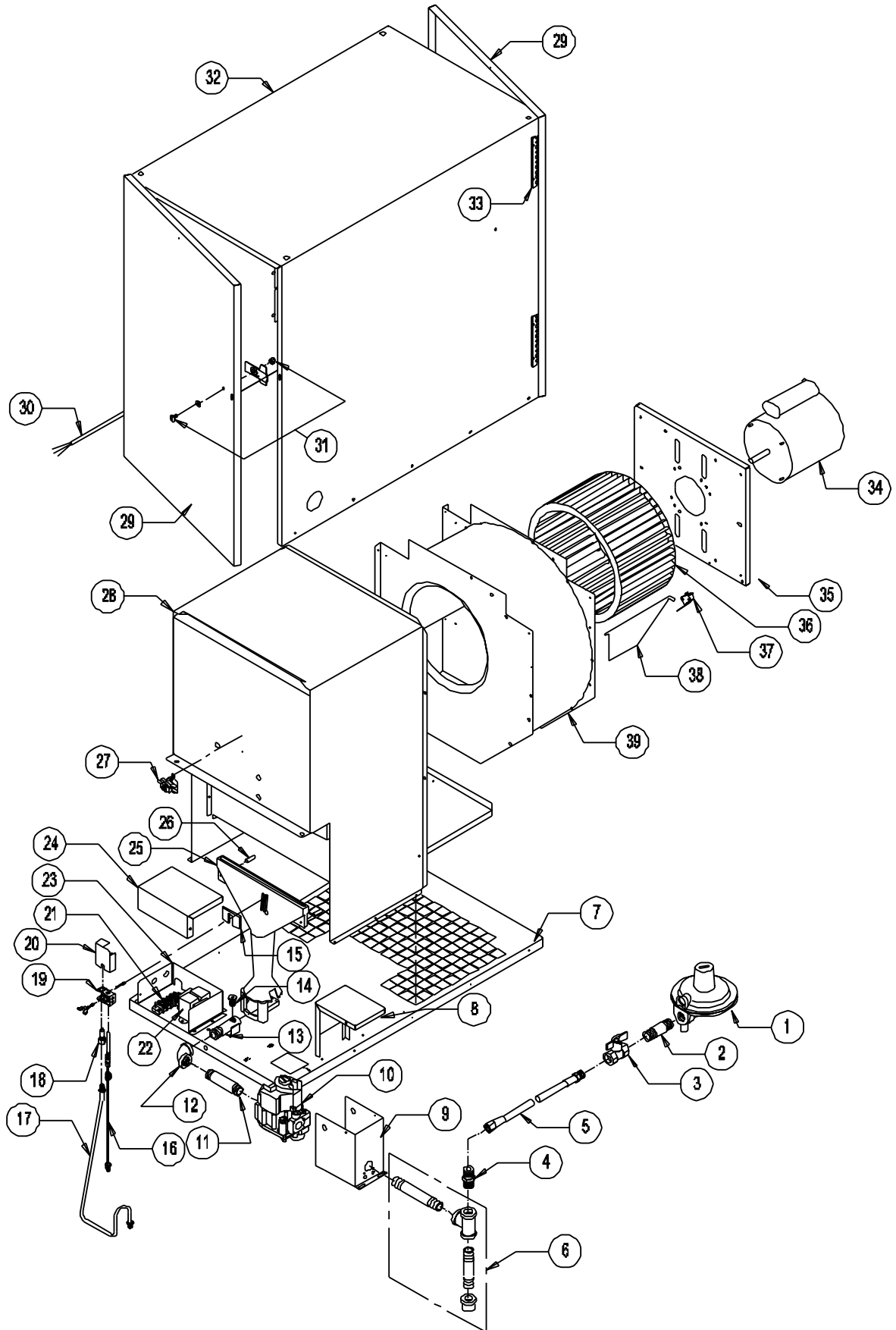

PARTS LIST

Item	Description	Part No.
1	Regulator (L.P. Gas)	400-20126*
	Regulator (Natural Gas)	500-07087*
2	Nipple, 12.7 mm x 89 mm	130-07148*
3	Valve, Manual Shut-Off	130-05548*
4	Adapter, Hose	310-02894*
5	Hose, 12.7 mm ID x 3 Meter	550-20714*
6	Kit, Sediment Trap	500-00815
7	Base	225-21051
8	Cover, Gas Control Valve	225-09287
9	Bracket, Gas Control Valve	225-09506
10	Valve, Gas Control (L.P. Gas)	500-22219
	Valve, Gas Control (Natural Gas)	500-22221
11	Nipple	130-07148
12	Elbow	130-01426
13	Manifold	420-09291
14	Orifice, Burner (L.P. Gas)	310-20049
	Orifice, Burner (Natural Gas)	310-21113
15	Gasket, Pilot (Natural Gas)	130-06974
16	Thermocouple, 750 mm	120-21196
17	Tubing, Pilot with Nuts	500-21126
18.	Orifice, Pilot (L.P. Gas)	130-07829
	Orifice, Pilot (Natural Gas)	130-06968
19.	Bracket, Pilot Burner	130-07831
20.	Shield, Pilot Barrel Assembly	500-21128
21.	Terminal Block (5 position)	120-08253
22.	Transformer, 240/24 VAC	120-20045
23.	Enclosure, Electrical	225-20028
24.	Cover, Electrical	225-20027
25.	Burner	320-03453
26.	Spacer	130-02687
27.	Switch, High Limit	130-05566
28.	Chamber, Heat	400-20024
29.	Door, Right or Left	225-20757
30.	Cord, Power	120-20359
31.	Latch Assembly	550-20959
32.	Case, Assembly with Doors and Latches	500-21129
33.	Hinge	130-05868
34.	Motor, 187 Watts	120-20668
35.	Mount, Motor	225-08647
36.	Fan, Wheel	130-09050
37.	Switch, Air Flow with Screws and Nuts	500-02680
38.	Sail, Air Flow	240-21035
39.	Housing Fan, with Sail, Air Flow Switch and Motor Mount	500-20250

* Optional Accessory

Label Identification

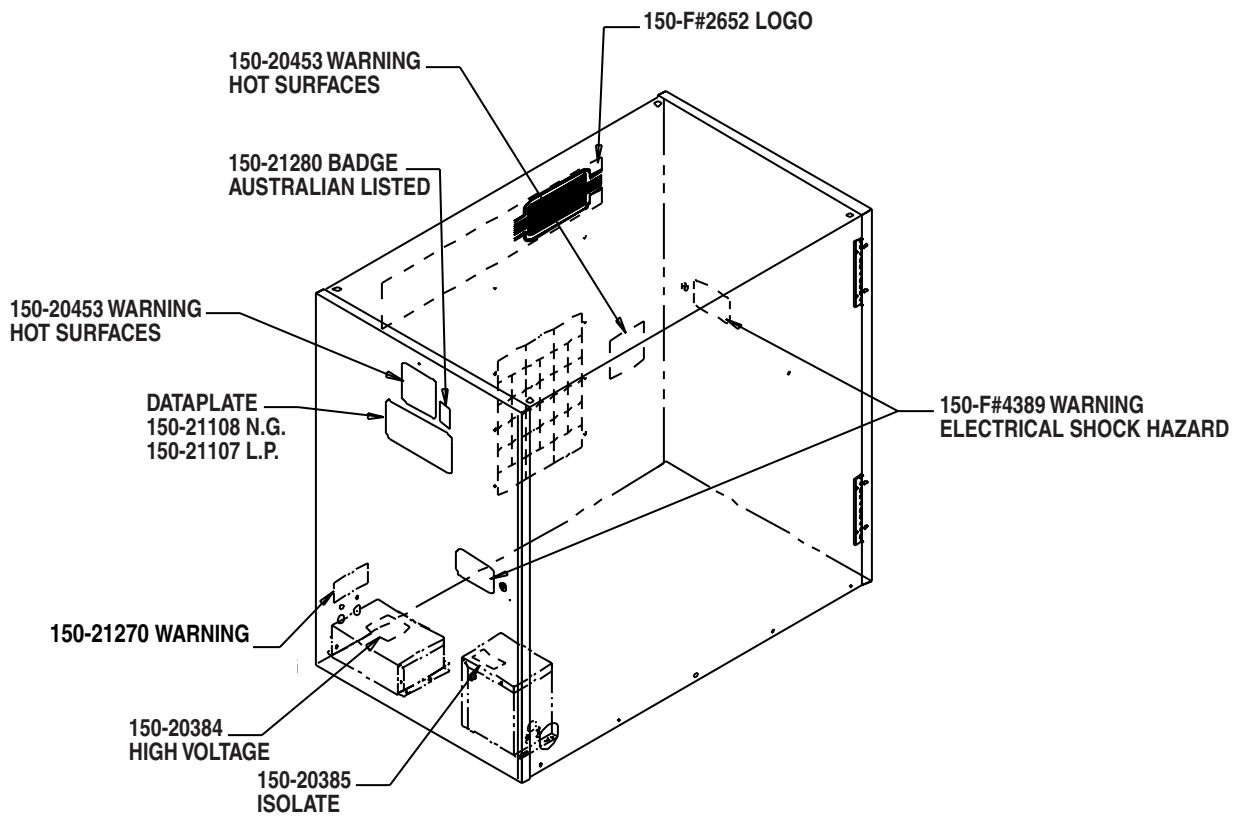

LABEL LOCATION ON BURNER END PANEL

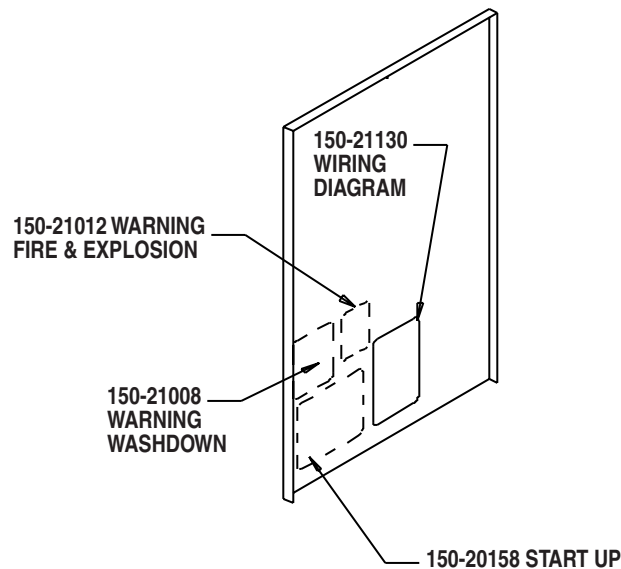

WIRE SELECTION TABLE

Description	Color	Length	Part Number
Wire, Air Flow Switch to High Limit Switch	Yellow	152 cm	120-20032
Wire, Limit Switch to Gas Control Valve	Yellow	56 cm	120-20570
Wire, Terminal Strip to Gas Control Valve	Green	61 cm	120-21272
wire, Terminal Strip to Air Flow Switch	Yellow	109 cm	120-20035
Wire, Terminal Strip to Motor	Brown	86 cm	120-20613
Wire, Terminal Strip to Motor	Blue	86 cm	120-20969
Wire, Motor to Base	Green/Yellow	112 cm	120-21124
Wire, Gas Valve to Base	Green/Yellow	61 cm	120-21125

FASTENER SELECTION TABLE

Description	Application	Part Number
Bolt	Burner Mounting	130-02692
Bolt, Eye	Hanging of Heater	130-07715
Chain	Hanging of Heater	130-07716
Nut, Cage	Case Top (for Hanging)	130-07708
Screw, Wing	Pilot Shield Mounting	130-07484
Stud	Pilot Mounting	130-07827
Screw, 1 1/2	Burner	130-02688
Screw, #8 x 3/8	High Limit Switch	130-06658
Screw, #8 x 3/8	All Other Applications	130-07288
Washer, Flat	Burner Mounting	130-01589

Warranty Policy

EQUIPMENT

L.B. White Co., Inc. warrants that the component parts of its equipment are free from defects in material and workmanship, when properly installed, operated, and maintained in accordance with the Installation and Maintenance Instructions, safety guides and labels contained with each unit. If, **within 12 months from the date of purchase by the end user**, any component is found to be defective, L.B. White Co., Inc. will at its option, repair

or replace the defective part or equipment, with a new part or equipment, F.O.B., Onalaska, Wisconsin.

A warranty card on file at L.B. White will automatically qualify a unit and its component parts for warranty consideration. If a warranty card is not on file, a copy of the bill of sale will be required to establish warranty qualification. If neither is available, the warranty period will be 12 months from date of shipment from L B. White.

PARTS

L.B. White Co., Inc. warrants that replacement parts purchased from the company and used on the appropriate L. B. White equipment are free from defects both in material and workmanship for **12 months from the date of purchase by the end user**. Warranty is automatic if a component is found defective within 12 months of the date code marked on the part. If the defect occurs more than 12 months later than the date code but within 12 months from the date of purchase by the end user, a copy of a bill of sale will be required to establish warranty qualification.

duration to the duration of the applicable warranty stated above. The remedies set forth above are the sole and exclusive remedies available hereunder. L.B. White will not be liable for any incidental or consequential damages directly or indirectly related to the sale, handling or use of the equipment, and in any event L.B. White's liability in connection with the equipment, including for claims based on negligence or strict liability, is limited to the purchase price.

The warranty set forth above is the exclusive warranty provided by L.B. White, and all other warranties, including any implied warranties or merchantability or fitness for a particular purpose, are expressly disclaimed. In the event any implied warranty is not hereby effectively disclaimed due to operation of law, such implied warranty is limited in

Some regions do not allow limitations on how long an implied warranty lasts, so the above limitation may not apply to you. Some regions do not allow the exclusion or limitation of incidental or consequential damages, so the above limitation or exclusion may not apply to you. This warranty gives you specific legal rights, and you may also have other rights which vary from region to region.

Replacement Parts and Service

Contact your local L.B. White dealer for replacement parts and service or call the L.B. White Company, Inc. at

1-608-783-5691 for assistance. Be sure that you have your heater model number and configuration number when calling.